

LINE	BBQ LINE
MODEL	LBK870
REF.	

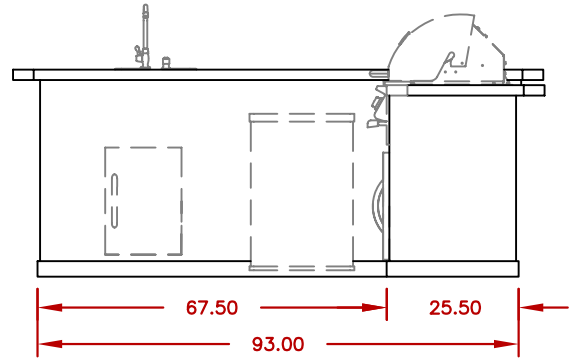

OPTIONS		
SYMB.	DESCRIPTION	OPT#
OPT1	NATURAL STONE TILE 12X12	SEE COLOR CHART
OPT2	CULTURE STONE	SEE COLOR CHART
OPT3	LED LIGHTING	OPTQ830A
OPT4	UNDERCOUNTER LIGHTS	OPTQ820L
OPT5	iPOD STATION W/ [2] SPEAKERS	OPTQ107
OPT6	UMBRELLA HOLE ONLY	OPTQ837

STANDARD FEATURES		
QTY.	SYMB.	DESCRIPTION
-	(A)	PORCELAIN TILE 12 X 12 (FIELD) (BORDER)
-	(B)	AMERISTONE STUCCO
-	(C)	3" BOTTOM TRIM (TILE ONLY)
1	(D)	4 BURNER P4 LP
1	(E)	STD. SIDE BURNER BURNER LP
1	(F)	OUTDOOR ELECTRICAL
1	(G)	30" DOUBLE ACCESS DOOR
1	(H)	18" SINGLE ACCESS DOOR
1	(I)	SST STEEL SINK W/ FAUCET & SOAP DISPENSER
1	(J)	SST REFRIGERATOR

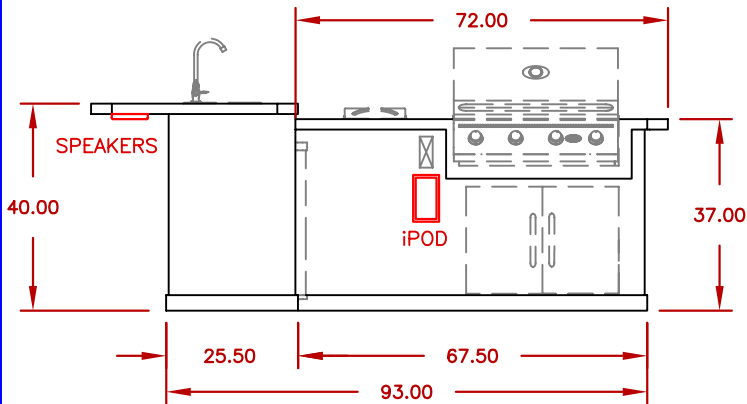
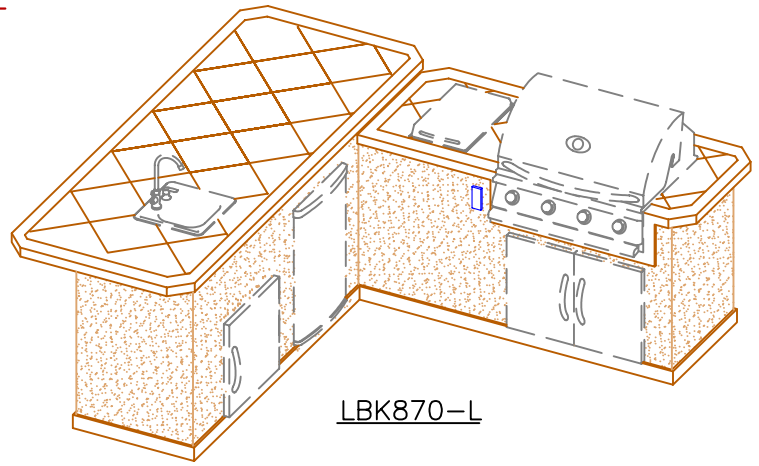
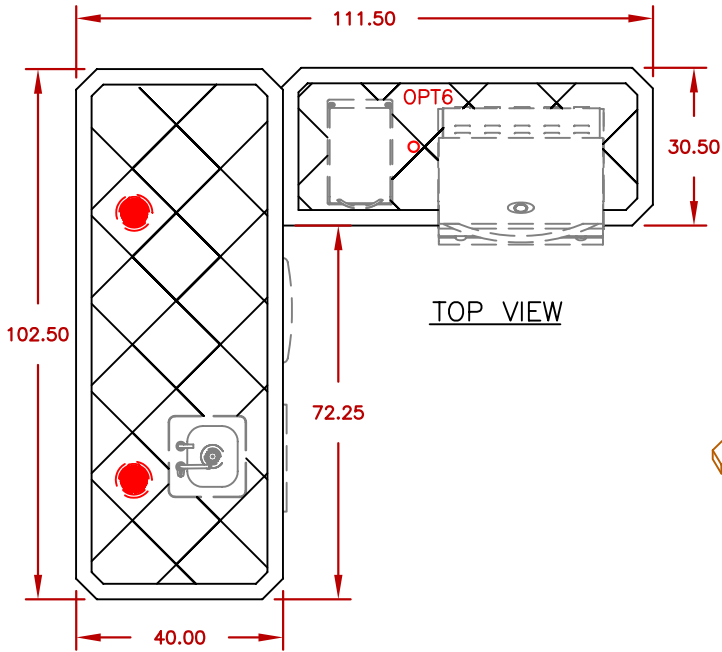
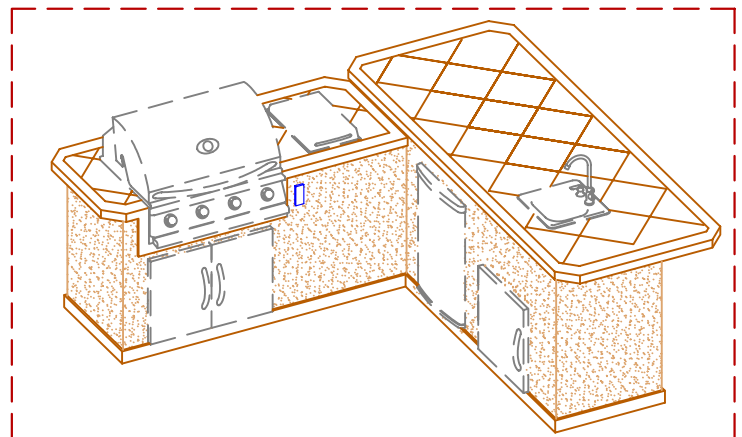

	TITLE	
	2017 BARBECUE LINE LBK SERIES LBK870	
SCALE:	DWG NO.	DWG BY
		G.GARCIA
REVISED	REV. DESCR.	DATE
		12/13/16

NOTE:
DUE TO OUR CONTINUOUS IMPROVEMENT PROGRAM, ALL MODELS
AND SPECIFICATIONS ARE SUBJECT TO CHANGE WITHOUT NOTICE.